

Maintenance Manual

This booklet has been designed and written to supply information regarding maintenance requirements for all makes and models built by KZ.

As the owner of a new KZRV product it is important to recognize the importance of performing routine maintenance during the warranty period. Just like oil changes in your tow vehicle—if proper maintenance is not performed the warranty coverage can be denied; this also applies to your recreational vehicle.

On the reverse side of the customer delivery sheet is the warranty coverage information. Note the twelve (12) exclusions, especially items four, five, six and seven, which are maintenance items.

Familiarizing yourself with this manual and using the maintenance chart in the back of the manual will help you make sure that proper maintenance is performed. But remember, maintenance is routine service and is not covered by warranty.

With proper and scheduled maintenance on your KZ RV we believe you will enjoy your RV for many years to come.

Happy Camping,
KZRV, LP

MAINTENANCE CHART				
	First Year		Second Year	
I. UNDERCARRIAGE		Date		Date
Wheel Bearings	Inspected		Repacked	
Lug Nuts Torqued	Inspected		Tightened	
Brake Shoes	Inspected		Adjusted	
Shackles	Inspected		Lubricated	
Steps	Lubricated		Lubricated	
II. EXTERIOR				
Metal	Washed		Waxed	
Fiberglass	Washed		Waxed	
Roof	Inspected		Sealed	
Roof Seams	Inspected		Sealed	
Corner Moldings	Inspected		Sealed	
Windows	Inspected		Sealed	
Slide Out	Inspected		Sealed	
Rear Lower Hinges*	Inspected		Lubed	
III. OPERATING SYSTEMS				
LP Systems	Leak Test			
Regulator	Leak Test		Adjusted	
Plumbing	Leak Test			
Electrical				
Battery	Tested		Add Water	
Lights	Inspected		Tested	
120V Breakers	Inspected		Tested	
GFCI	Inspected		Tested	
IV. APPLIANCES				
LP Connections	Inspected		Tested	
Stove			Tested	
Water Heater			Tested	
Plumbing System	Inspected		Leak Test	
Refrigerator			Tested	
A/C (120V Operation)			Tested	
* Sportster "Toy Haulers" Only				

TABLE OF CONTENTS

Chapter I—Undercarriage

Frame.....	1
Coupler	1
Stabilizer Jacks.....	1
Jacks.....	2
Tires.....	2
Wheels.....	3
Axles.....	4
Brakes.....	6
Springs/Shackles.....	8
Steps.....	9

Chapter II—Exterior

Metal.....	11
Fiberglass.....	11
ABS Plastics.....	11
Exterior Roof.....	12
Extrusions and Vents.....	13
Vinyl Tire Covers.....	13
Slideouts.....	14
Sportster Doors.....	15
Tents.....	15

Chapter III—Systems

Propane System.....	17
Plumbing System.....	18
Electrical System.....	19

Chapter IV—Appliances

Furnace.....	21
Water Heater.....	22
Stove, Range, Cooktop.....	23
Refrigerator.....	24
Air Conditioner.....	26

Chapter V—Interior

Paneling	29
Linoleum / Vinyl Floor	29
Carpet	29
Hardwood Floor	29
Counter Tops	29
Solid Surface Counter Tops.....	29
Window Mini Blinds.....	31
Day Fabric Shades	31
ABS Plastic Components.....	31
Soft Touch Ceiling	31
Drapes	31
Cushion Covers	31
Furniture.....	32
Windows	32
Smoke Alarm.....	32
Propane and CO Detector.....	33

Chapter I — Undercarriage

Your KZRV recreational vehicle is designed to be as maintenance free as possible. However, all moveable vehicles require some care to reduce the possibility of unwanted breakdowns during travel. Maintenance of your RV may not seem necessary at the time of purchase, yet it is very important to keep your coach in it's best condition for your enjoyment. Normal maintenance is required to maintain warranty coverage, reduce wear, and prolong the life of your coach.

1. FRAME

The steel frame on your KZ recreational vehicle is cleaned with a high pressure phosphate spray wash that removes oils, dirt, and residue. After cleaning the frame is placed in an oven at 200°F, high quality, water borne paint is then applied. A final curing process is then applied to produce a quality paint application.

No matter what quality or type of paint process is used, we must remember that during travel the frame is exposed to stones, sand, road debris, and any other objects found on the road. These items will cause scratching and chipping of the paint inviting rust to begin from moisture. Your frame needs to be inspected and examined every year to touch up or repaint as normal maintenance. We suggest this be performed each fall before storage to guard against winter moisture.

The paint to use is a gloss black, ozone safe exterior paint with no fluorocarbon, in a spray can.

You may wish to purchase a commercial rust proof undercoating treatment, such as, Ziebart®, etc. However, even such higher priced treatments are subject to road debris and damage.

2. COUPLER (Travel Trailers)

For the ball on your hitch use a light amount of chassis grease. Lubricate the coupler's pivot points with silicone spray. Avoid grease or oil as they will draw dirt, potentially damaging the coupler.

3. STABILIZER JACKS

On item #4 (illustration), drive screw, spray silicone is recommended to be applied two or more times per year. DO NOT use oil or grease as it will attract dirt and grit causing gradual deterioration.

Should jacks become rusty you may wish to paint them; to stay more attrac-

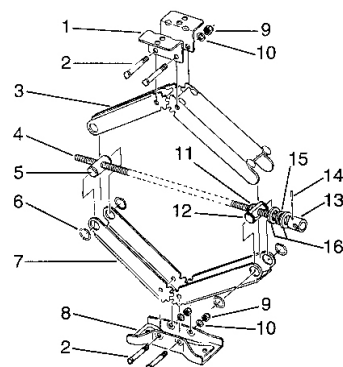

tive and easier to function. Avoid painting the main operating screw.

4. JACKS

A. Travel Trailers & Truck Campers

On the top of the jack is a metal cover attached with a wire spring clip. Remove cover and inspect gears for grease. Re-grease if there is none there or it has dried out. Some brands of jacks have a hole placed just below these gears to insert oil for lubrication of the ram so it will move smoothly, ten to twenty drops annually will do the job.

B. Landing Gear Jacks (Fifth Wheels)

- a. Extend landing legs as far as possible, clean drop tube and inner ram tube. Coat exposed surface or tubes with silicone spray lubricant.
- b. Coat inside of handle alignment tube with silicone spray lubricant.
- c. Oil shaft bushing in gear box and leg gear heads with SAE 30 oil.
- d. Lubricate gears in gear box and landing gear heads with extreme pressure grease.

On 2000 lb. rated jacks there is a flat plate on top attached with spring clips. (Not in production since 2003) On 3000 lb. & 4000 lb. jacks there is a metal cover on top of jack. Remove these covers to perform item "d." 2000 lb. jacks are obsolete and not available after January 1, 2004.

C. 12 Volt DC Motor

For Electric Drive Motor Landing Legs, check wiring connections at battery, twice each year. Clean terminals with a solution of baking soda and water. Cover with thin coat of grease.

NOTE: Electric Drive Motor is lubricated at factory and requires no further lubrication.

The Electric Drive Motor Landing Leg system is protected by a 30 amp fuse. If replacement is necessary, replace only with a Buss Type AGC-30 fuse or equivalent, available in automotive supply stores.

5. TIRES

Tires installed on your RV are matched to the weight of your coach according to the rating of the tires. The most important item in tires is to inspect and test air pressure no less than once per week, perhaps daily during travel. Correct PSI air pressure is listed on each tire as per rating. When air pressure is not maintained as

specified tires will run hot, especially in summer months, and blow outs can occur. Pressure must be always be checked when tires are cold, preferably in the morning. NO NOT adjust or lower tire pressure when warm as it will be too low when cool. All tire pressures rise when tires are moving on roadway. A tire is considered "cold" after 3 hours of not moving.

6. WHEELS

All wheels, due to their location, are subject to road conditions, moisture, dirt, etc.

White steel wheels are powder coated paint. Since they are painted, to maintain its nice appearance, wash them with soap and water as often as desired. Should you find scratches or chips in the paint, clean and paint to protect against rust and further damage.

Aluminum wheels require the some type of mild soap and water. DO NOT use harsh soap or chemicals as they may discolor the wheel's finish.

When changing a tire and wheel, always start the lug nuts by hand before using any power tool to tighten wheels, to avoid cross threading.

After your first trip, check the wheel lugs periodically for safety. The wheel lugs should then be checked after winter storage, before starting a trip or following extensive braking. The size of bolts or nuts is 13/16 inch. **Over torquing wheels is as dangerous as under torquing and can damage the wheel.**

Wheels must be tightened and torqued to 95-120 maximum foot pounds, preferably 95 to 100 foot pounds.

Each time a wheel is changed, re-torque after 100 and 300 miles.

Trim Rings and Center Caps

These stems may be plastic or metal. Both require cleaning and polishing. Plastic will tarnish and metal rust if above care is not performed.

Tighten each lug nut in the order shown to the torque shown in the chart.

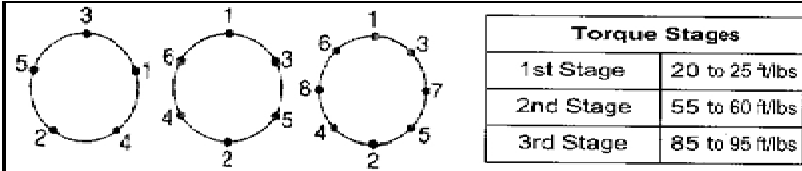

Torque Stages	
1st Stage	20 to 25 ft/lbs
2nd Stage	55 to 60 ft/lbs
3rd Stage	85 to 95 ft/lbs



FASTENER TORQUE WARNING

It is important to maintain proper torque to provide safe and secure attachment of the wheel to the hub/drum. Be sure to use wheel nuts that are compatible with the coin of the wheel. Improperly torqued wheel nuts can cause the wheel to separate from the wheel mounting surface during operation. This could result in property damage, seri-

7. AXLES

The axle beam (tube) itself requires no maintenance unless it has become bent, causing unusual tire wear, camber or toe in/out. If this occurs the beam needs to be replaced or realigned to prevent continuous tire wear. Special alignment equipment is required to correct this condition.

A. Bearings

Wheel bearing are enclosed with a dust cap on outside and a seal on the inside, protecting bearings. Beginning in year 2004 a new method is being used called "Ultralube®", containing a grease zerk behind a black rubber cover or dust cover, allowing the owners to place grease into bearing with a grease gun.

There is no need to lift the trailer before greasing axles equipped with Ultralube:

1. Remove the rubber plug from grease cap
2. Insert grease gun on the grease zerk.
3. Place three to five shots of grease in each zerk every 3000 to 5000 miles. Over greasing will put grease on brake shoes.
4. Reinstall rubber plug.

ULTRALUBE®



The Ultralube® system DOES NOT remove the need to repack bearings as listed below. We recommend repacking once each year (every other year maximum) or 6,000 miles. Also inspect bearings and hubs for any damaged components when you have it apart.

All wheel bearings in your coach are pre-greased at the point of assembly. At six months or 6000 miles of use, inspect the bearings for lubrication and wear.

Wheel bearings require visual inspection, cleaning, repacking, and inspecting the overall condition.

B. Repack Bearings

Before repacking bearings, take bearings out of hub and wash all old grease and grime out of bearings and hub with solvent cleaner. Use a high temperature, automotive type wheel bearing grease produced by a reputable manufacturer. The soap type should be lithium complex or equivalent. Use NLGI Grade 2 product with a minimum dropping point of 440°F. Repack by hand or bearing packer. Grease must be fully forced into cavities between rollers, cone, and cage of bearings. Repack by hand or bearing packer.

Always replace bearings and races as a set. Install races (new hub/drums should have races already installed) using a mild steel drift or bar. Do not use hardened steel or brass bars as they may damage, chip or leave deposits on the races. Final setting of the race against the shoulder should be checked with feeler gauges and be within 0.002" of the shoulder in the hub/drum.

After bearings have been packed with grease, place inner bearings into correct position, seated into race or cup. Place a new seal over bearing (never reuse previous seal). Use a seal driver or hard rubber mallet and tap gently. Be sure seal is seated fully and completely.



CAUTION

Over packing the hub results in grease seeping out of the dust cap and wheel seal.



WARNING

Improper seal or bearing installation or adjustment or insufficient maintenance can lead to wheel bearing failure which could cause the hub/drum and wheel to separate from the axle during operation

1. To get the proper "feel" for bearing clearance, the spindle nut must turn freely on the spindle and the brake must be readjusted so that there is no drag on the drum.
2. While slowly turning the hub/drum tighten the spindle nut to approximately 20 ft/lbs then loosen to first notch in nut. This is especially important if new bearing races have been installed.
3. With drum stationary (do not rotate), retighten the spindle nut to 7 ft/lbs (zero clearance) then back off one slot (0.001"-0.010" end play) and align cotter pin hole. Insert cotter pin and bend both ends over end of spindle. Install grease cap.

8. BRAKES

The brakes on your coach are 10" or 12" in diameter depending on the weight of the trailer. They function from 12 volt DC power supplied through brake control from your tow vehicle.

These brakes are NOT self-adjusting. You will need to adjust brakes manually as outlined in the next several pages or have your selling dealer perform this operation.

When a coach's brake system is new, the brake shoes and drum are not completely meshed together. This first adjustment should occur at 200 to 1000 miles or when brakes have been engaged 100 times, referred to as "burnishing." After initial adjustment brakes should be readjusted every 3000 miles. Under adjustment can cause poor braking and the adjuster wheel to fall apart, resulting in having no brakes and possible damage to other components. Use a qualified technician to perform this maintenance procedure.



CAUTION

Always place stationary jack stands or blocks under frame to guard against jack failure.

1. Lift trailer. **Do not remove the wheels or hub/drum assembly.**
2. Locate the adjusting slot at the bottom of the backing plate and remove the protective cover.
3. While spinning the wheel, use a standard brake adjusting tool or the blade of a screw driver to rotate the star wheel until there is a heavy brake drag.
4. Loosen until the wheel turns freely about 3/4 to one full turn.
5. Replace the protective plug to keep dirt and moisture out.
6. Replace all parts and lower trailer.
7. Repeat procedure for other wheels. Never adjust just one brake. It is recommended that **all** brakes on the trailer, or at least both brakes of one axle, be adjusted at the same time.

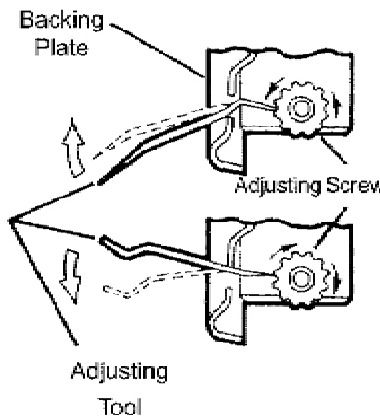



WARNING

Improper brake adjustment can result in reduced brake performance or loss of brakes. Reduced brake performance can lead to property damage, serious personal injury, or loss of life.

A. Brake Shoes

While the hub/drum is removed the brake shoes also require full inspection for:

1. Normal wear - 1/16" is minimum.
2. Cracking from heat - Hairline heat fissures are not uncommon in bonded shoes and pose no cause for concern. If there are any questions concerning the severity of cracking, consult with an expert. If the lining is worn to 1/16" or less, or shows irregular wear or contamination from foreign substances, the shoes should be replaced with original AL-KO parts. If cracking is severe replace the shoes.
3. Dirt and other contaminants.
4. The springs are secure and have good tension.



WARNING

Brake shoes should always be replaced in pairs, both brakes on the same axle. Failure to replace in pairs can result in reduced brake performance or loss of brakes which could result in property damage, serious personal injury, or loss of life.

Brake shoes as a component subjected to daily use and normal wear. Shoes are warranted for workmanship but not for normal wear.

B. Brake - Hub/Drum

While the hub/drum is removed for other service work be sure to inspect the drum for :

1. Cracks in casting, inside or outside.
2. Rough spots, may require sanding.
3. Heat distortion (bluish color).
4. Out of round drums (high spots).
5. Deep scoring of 0.030" and over.

Items 4 and 5 require use of a brake drum micrometer. Resurfacing of the drum may be required.

Resurfacing the Brake Drum

A standard drum lathe may be used to machine the drum surface. Do not exceed the maximum diameter cast into the brake drum. The drum should be replaced if it must be bored more than the maximum diameter cast in the brake drum.

Armature surface machining is a difficult process with most drum lathes and is not recommended. If it resurfaced it should be machined to a 120 micro inch finish and must have 0.060" above the stud heads. Do not remove more than 0.030" of material.

Be sure to remove any metallic chips and contamination resulting from drum machining. Clean drum carefully before reinstalling.



WARNING

Heavily scored, worn or oversized drums can result in reduced brake performance or loss of brakes. This could result in property damage, serious personal injury, or loss of life.

C. Brake Magnets

This component transfers the 12 volt power into action by engaging itself to the armature causing the brake to engage with drum surface. Inspect the magnet for standard or abnormal wear. Generally a magnet "works" or it is "dead" requiring replacement.

9. SPRINGS / SHACKLES

All suspension components should be visually inspected at least every 6 months or 6,000 miles. Check for loose fasteners and torque to proper values.



FASTENER TORQUE WARNING

Improper torque can cause component failure and the axles to become detached from the frame. This could result in property damage, serious personal injury, or loss of life.

A. Springs

Springs themselves require no maintenance other than inspection for breakage or cracks. Painting springs and other components retards rust, improving the appearance of the items.

If spring(s) are broken replace immediately as driving will cause additional strain on the other springs.

B. Shackles

Bolts and shackle plates need to be inspected twice per travel season or more if traveling consistently. Bolts are not expected to turn which causes nylon bushings inside of the spring eye to wear rapidly, causing the holes in shackles to wear oblong. When this condition occurs you MUST replace bolts and shackles.

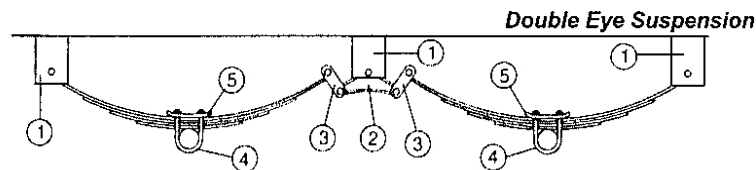

① Spring Hanger ② Equalizer ③ Shackle Link ④ U-Bolt ⑤ Tie Plate

Bolts have ridges next to the head, not visible in installed position. When assembling the bolts it is very important to prevent the bolt from turning which will cause damage. Turn the lock nut(s) only.

Heavy duty shackle kits are available with brass bushings and greasable zerks on the bolt heads. Your dealer can assist you with obtaining such components.

10. STEPS

The step assembly is subject to all types of weather elements and requires the following maintenance:

Covering nicks and scratches :

1. Seal any nicks or scratches with an automotive grade primer to prevent rust.
2. Once the nick or scratch has been sealed, cover the damaged area with an automotive grade high-gloss paint.

Lubricating the Mechanism

1. Carefully clean the area around the pivot points (the rivets involved in the motion of the mechanism).
2. After cleaning, lubricate the pivot points (to pinpoint this area, locate the washer between the parts). An automotive grade, non-staining lubricant is recommended. Silicone spray is also good, use it monthly during travel use.

We suggest lubricating the mechanism every 30 days during usage. During non-use, lubricate at least each spring and again each fall before winter storage.



CAUTION

To prevent the possibility of a person slipping on the steps:

1. Lubricate **ONLY** the pivot points
2. **Wipe off any excess lubricant and clean the step carefully to be sure no excess lubricant is on the step assembly.**

NOTE:

Paint on axles and springs is only a primer coat. You may wish to repaint as part of normal maintenance.

Chapter II — Exterior

1. METAL

Aluminum skin is pre-painted as prepared from supplier with polyester automotive paint finish. To clean, use a mild detergent soap and water.

Use an automotive type of wax or polish; same as you may use on your tow vehicle. By waxing your RV once per year, it retains its nice, new appearance.

2. FIBERGLASS

Fiberglass components used in KZ coaches are several different type:

- a. Front and rear caps are built in a mold, using gel type of fiberglass components.
- b. For sidewalls, there are two types used - "Gel coat" and "Lamilux."

Cleaning on all fiberglass materials, use a mild detergent and warm water using a soft brush or rag. For tougher stains such as found around drip rails, awning rails, or windows, a special cleaner may be required.

Waxing on Gel Coat Material

As the gel coat begins to lose its gloss from constant exposure to the natural environment and pollutants, it will require some special attention to restore the original gloss and color. Good polishing with a self-cleaning automotive wax will restore most of the original gloss. A fall and spring wax job is generally all that is needed to maintain the original appearance. If the surface has been allowed to weather badly, and cleaning and wax polishing does not restore the finish satisfactorily, then compounding will be necessary. The finish is totally impervious to chemicals and weathering. Imagine what a brand new car could look like if allowed to sit outside for years with no cover and no washing or waxing. With the same minimum maintenance you would ordinarily give your new automobile's finish, your RV gel coat finish will retain its depth of color and gloss for years.

3. ABS PLASTICS

Frontier and Ultra Lite lower fronts and fenders will retain their original condition with general washing and polishing. These surfaces are not as hard as fiberglass and can scratch. DO NOT use abrasive soaps or polishes on ABS plastics.

4. EXTERIOR ROOF

Two types of roof material are used on KZ products. Aluminum material is a smooth mill-finish requiring little care. Washing with soap and water plus rinsing should suffice. There is no hard substrate material underneath and aluminum will show slight waves due to sun and heat causing expansion of the aluminum material.

Rubber roofing is a vinyl/plastic mixture called "TPO" (Thermo Plastic Olefins) or EPDM full rubber cover.

The proper care, cleaning and maintenance of your TPO roofing is quite simple because of the basic properties and longevity of the material itself.

Periodic cleaning is the primary maintenance. Alpha Systems suggests using Murphy's Oil Soap with a soft nylon brush or sponge. DO NOT USE solid or granulated cleaners, as they will mar the natural finish.

DO NOT USE Armor-All or other oil/solvent base cleaners as they will leave a slick surface.

A good thorough cleaning with some elbow grease and the suggestions above should keep your roof looking good and remove most stains. For more stubborn stains, you should contact your authorized dealer.

If you keep your Royal Tuff-Ply TPO roof clean, you will be performing the primary maintenance necessary to keep it looking good and extend its longevity.

Annual inspection of the roof is suggested. Check the membrane for possible damage and check the caulk/lap sealant used in all termination vent areas, around roof vents and any other attachments. Be sure sealant is fully attached to roof membrane and not coming loose.

Royal Tuff-Ply is UV resistant. It will not retain odors or rot. On top of roof a seam connects front panel on cap to roof material. A putty tape seals the seam, which is covered with a flat extrusion plus roof sealant, to be inspected and resealed as required. This needs to be done twice per year, spring and fall.



CAUTION

At least once per year, inspect all roof seams; front, rear and around all vents. Remove any loose sealant and reseal these areas. Use self-leveling sealant, "Alpha Systems #1015," a non-hardening sealant. Failure to inspect and correct as needed will void the warranty coverage, classed as negligence.

5. EXTRUSIONS AND VENTS

All components installed on the exterior of your coach have some type of "putty tape" placed between the mounting flange or surface to guard against water entry and leakage.

Additional sealant, referred to as "cap seal" is used to protect along the edges of extrusions or be a secondary surface sealant. All of these sealants are subject to weather elements such as UV rays from the sun, rain, snow, cold, heat, air pollution, frost and other exposures causing dry-out, shrinkage and possible cracking.

Cap seal must be examined each year, preferably each spring and fall, for looseness, cracking, and separation from any attached surface. If upon inspection you find the above conditions, repairs must be made. These conditions will permit water to enter slowly and eventually cause major damage to your RV.

Corner and roof extrusions have putty tape sealant between the components. This material can and will also dry and/or crack from weather elements, permitting leakage and eventually major deterioration. KZ advises the owner to remove these extrusions, clean out old putty tape, and replace with new sealant material every five years.

Windows, entrance doors, and cargo doors use a black closed cell foam tape, for sealant needs, plus an inside butyl tape. These sealants may also deteriorate over time, lose its memory, shrink with weather conditions, etc., over a period of five years.

All sealants must be maintained to prevent failure plus leakage damage.

For best results, sealant requirements are:

1. Resistant to checking
2. Resistant to shrinking
3. Dry's rapidly
4. Adhere to metal and fiberglass
5. Expand and contract with temperature changes
6. Color should match

Suggest Sealants

Geocel = #2300

Quad = pro series

Silaprere = Royal Seal 1000

6. VINYL TIRE COVERS (OPTIONAL)

To clean vinyl tire covers use the same soap and water as used for washing your coach. Sun rays may cause "bleed through" on the cover from the black rubber in the tire. To minimize this condition use a separator such as a garbage bag, thin vinyl, etc. between the tire and cover.

7. SLIDEOUTS

KZ uses numerous variations types and variations of slide-out systems, both power driver and manual push/pull operation.

1. **Below Floor System:** This system uses a rack and pinion system which means it runs on a cog track matched to a gear on the motor shaft. To lubricate the track: a) run room out fully, b) spray silicone spray or dry moly lubricant onto track, and c) run room in to lubricate the gear on the motor shaft. On none of the enclosed frames can you lube track without extending room.
2. **Bedroom System:** This system uses a similar system with complete assembly inside of coach under bed. Raise bed board and mattress to gain access to lubricate track as described above (#1).
3. **Above Floor System:** This slide out uses a gear and ladder type track. Twice per year spray gear and track with silicone spray. Since all parts are inside of coach less moisture and contaminants will be attracted to the mechanism.
4. **Quick Super Slide (QSS) System:** This is a fully manual operation. Simply disengage two latches at rear main rails in frame (pull straight up to release), open entrance door for air transfer and pull room out until latches reset on both sides. The only maintenance you can do is lightly spray inside of roof track where rollers move and heavier spray on outside ram arms going into main rail. No oil or grease is to be used, in order to avoid dirt and grit.
The two rollers at the rear main tube may be lubed with silicone spray along with its mounting pin. Two more rollers are inside of steel ram and are not accessible.
As with all slide outs, a hole is built into the sidewall to accept the moveable slide out room. With this convenience it gives you another chance for moisture entry. Continuously observe and inspect for moisture entry. Ignoring any leakage will void and nullify warranty coverage.
5. **Bedroom System:** This system uses a similar system with complete assembly inside of coach under bed. Raise bed board and mattress to gain access to lubricate track as described above (#1).
Lubricate slide in bedroom two times per year and the exterior system (#1) one time per month, especially during full use.
6. **Rear King Slide—All Slide Extension**
All pulleys and cables are fully enclosed, except outer ends of 8 cables attached to slide. No maintenance is needed on this system.

General Suggestions:

Avoid using oil, WD40 or greases as they will attract dirt causing greater problems and wear. Lubricate slide in bedroom two times per year and the exterior system (#1) one time per month, during use or once in spring and once in fall with minor use.

Gear box on above slides requires no additional lubrication. Seals on extrusions need to be inspected for proper fit, no cuts or snags. Such imperfections may permit water to enter causing moisture damage. Inspect these seals two times per year.

Be sure slide outs fit well as some times additional adjustments need to be made. Contact your dealer for such adjustments on all slide outs.

8. SPORTSTER DOORS

On the rear door hinge assembly there is a grease zerk which requires grease gun lubrication. Failure to keep this hinge from rust and seizing up, causing the hinge to break, is responsibility of the owner. Grease this monthly to keep the hinge lubed and operating freely.

Second style has removed of upper cables reel assembly, now using 2 to 4 large coil springs in lower hinge assembly. No greasing is now required. Use only silicone spray evenly 30 days during usage.

9. TENT(S) ON COYOTES

The tent(s) on your Coyote trailer is manufactured with mostly vinyl and polyester fabric laminated to vinyl, with vinyl exterior. Two tendencies that you may discover in any tent assembly are condensation and possible minor leakage on the first several times the tent is used.

A. Condensation

Since this material can't breath you may—depending on weather conditions, temperature variance, and furnace usage—experience some condensation inside of the coach, more so at night than day time.

Such condensation can be reduced or possibly eliminated by opening the upper corner of bunk end panel, 1/2" to 1", folded over to allow a small quantity of air to move across the roof panel, at the end which has the head of the sleeping person.

B. Leakage

ALL VINYL TENTS NEED TO GET WET ONE OR MORE TIMES TO SEAL THE NEEDLE HOLES. Your tent may leak the first time it gets wet around the seams. Do not be alarmed. The tent is sewn

with special thread that swells up and seals the needle holes after it has been wet 1 to 3 times. Rubbing a wax candle over sewn seams after the first rain may also assist in quicker sealing.

Preventing Leakage During Use

- Do not rub against walls, roof or canvas windows when wet or when raining.
- Do not place objects against tent walls.
- Do not over extend or over stretch your tent.
- Do not spray insect repellent or hair spray on fabric as these items may destroy water repellency of this fabric.
- Do not put tent away in wet conditions. This might be difficult when leaving campsite in raining conditions. Within 48 hours, be sure to open the tents and set them up completely so they can dry out.

ALWAYS VENTILATE AND DRY THE TENT WITH BOWS AND BRACES IN PLACE as soon as possible after each exposure to moisture. Mildew is always the result of negligence.

The plastic windows have a -20° cold crack rating. Do not raise the tent to maximum height in extreme (0 degree) weather as the windows may shatter.

C. Cleaning

To clean your tent use mild soapy water and a soft bristle brush. Rinse with hose using spray nozzle. Repeat if necessary.

- Do not use solvents, detergents or aerosol cleaners on or close to unit. An agent used in most sprays as a propellant will damage or destroy water repellent finishes (hair spray, deodorants, insect sprays, etc.)
- If you have a stain or specific problem, contact your dealer before trying solvents and cleaners that may damage your unit and void your warranty.
- Vinyl bunk ends may be cleaned with an automotive vinyl cleaner.

[This page intentionally left blank.]

Chapter III—Systems

1. PROPANE SYSTEM

Your system to feed propane fuel thru your piping system needs to be inspected for leakage at least once per year, preferably in the spring before you begin your camping season.

The best method to test the system is to use a manometer, an instrument used to measure the operating pressure at 11" of w.c., as well as leak testing.

You may also use soapy water that does not contain chlorine or ammonia, applied on the brass fittings looking for bubbles indicating leakage. If so, repairs must be made before using your coach for safety reasons.

This system includes all copper lines, brass fittings to each appliance, hoses, regulator, and steel manifold lines with attached brass fittings.

Several Components require yearly maintance:

Propane regulators must always be installed with the regulator vent facing downward. Regulators that are not in compartments have been equipped with a protective cover. Make sure that the regulator vent faces downward and that the cover is kept in place to minimize vent blockage that could result in excessive gas pressure causing fire or explosion.

The regulator has the only moving components in the propane system. It's sole function is to reduce the high and varied pressure from the propane containers to safe and consistent low operating pressure. The small inlet is the first stage, which reduces the container pressure to 10-13 pounds.

The second stage then reduces the 10-13 pound pressure to an operating pressure of 11 inches w.c. (water column) or 6.35 ounces of outlet pressure to your appliances. The second stage is adjustable and may need to be adjusted for precise operation. We suggest this to be normal maintenance and preformed once per year. Do not make this adjustment without a manometer. The instrument is required to read actual pressure.

If pressure is too high, it affects performance and safety. Should pressure be too low, appliances will not operate correctly. An authorized and competent technician with proper equipment should perform such tests and adjustments, as may be required.

The best method to test the system is to use a manometer, an instrument used to measure the operating pressure at 11" of w.c., as well as leak testing.

As a manufacturer we suggest you have your selling dealer's service center perform this test unless you have the proper equip-

ment and full understanding of how to perform this test. You may also wish to use a local reputable RV service center to perform this function.

2. PLUMBING SYSTEM

Maintenance to plumbing system is minor, there are two items of importance.

Instructions to sanitize your portable water systems are found in your owners manual.

Finding and searching for water leaks is important and may be difficult to find.

A good method to search for a leak is to:

- Place water into fresh water tank
- Fill the system with water
- Start the 12 volt water pump to full pressure till pump shuts off
- If pump cycles within ten minutes, search for a water leak

If the coach is equipped with an ice maker and/or water filter, don't forget to review these connections as well.

A. Toilet Stool

1. Deodorizing—This toilet was designed to be compatible with Thetford brand holding tank deodorants.
2. Cleaning—Use Thetford **Aqua-Clean™** n o n - a b r a s i v e cleaner with a soft bristle, non-abrasive bowl brush, sponge or soft cloth. **DO NOT USE SCOURING POWDERS, ACIDS OR CONCENTRATED CLEANERS, WHICH CAN DAMAGE SURFACES, PLASTIC PARTS AND RUBBER SEALS. FAILURE TO DO SO CAN VOID YOUR WARRANTY.**

B. Maintenance for Holding Tanks

The following maintenance is recommended by our holding tank suppliers to keep your tanks clean and keep the probes free of debris and build-up.

- Gray (Waste-Water) Tank. Fill tank with 10-12 gallons of warm water. Add a degreaser such as a citrus cleaner or Dawn dish soap. Leave solution in tank while you are traveling. Rinse and drain tank.
- Black (Sewer) Tank. Fill tank with 10-12 gallons of water. Add one bottle of drain cleaner, such as Drano or Liquid Plumber. Leave the solution in tank while traveling. Rinse and drain tank.

Remember—the more you rinse tanks, the cleaner they will be to avoid incorrect readings on probes and gauges on the monitor panel system.

Flush Kit—Option

Kit to flush black water holding tank is available on most models is designed to maintain and clean your tank. Never attempt to flush tank until it is empty of water and solids.

3. ELECTRICAL SYSTEM

A. 120 Volt AC

Turn off all breakers, plug coach into 120 volt AC, shore power, turn on 30 or 50 amp main breaker and then each breaker following. This procedure indicates your 120V system is working correctly and feeding power throughout your coach.

GFCI

This device is designed to protect individuals from improper grounded conditions, especially on the outside while touching exterior components.

To test this receipt, press the test button two times per camping season to assure proper operation. Now press the “Reset” button. Should you not be able to reset, replace the receipt or find an electrical technician.

B. 12 Volt DC

As a manufacturer, we suggest that each spring you inspect for any loose wires and/or loose connections in the load center and tighten if loose. Also, inspect fuses for continuity and operation.

Battery

A 12 volt battery (deep cycle preferred), whether supplied from manufacturer or dealer, require constant inspection and maintenance.

To preserve long life in any battery three important functions are required:

- a. Charge battery every 30-60 days to keep fully charged during non use, especially during winter months
- b. Certain types require water to be checked and added as necessary. Keep water above cell mass to avoid permanent damage.
- c. Store battery in a cool place when not in use, around 40°F.

A fully charged battery will measure at 1.265 specific gravity. A discharged battery will measure at 1.120 specific gravity or 11.7 volts DC. A hydrometer is required to measure "specific gravity."

Most batteries with deep cycle rating require water to be added as needed. This depends on the amount of draw time that your converter is in operation.

Use distilled water if possible as it is nearly mineral free. Not keeping batteries charged will result in shorter life expectancy.

Be sure to keep terminals clean at all times to ensure good contact.

[This page intentionally left blank.]

Chapter IV—Appliances

1. FURNACE

The furnace in your KZ RV does need some normal maintenance attention, preferably once each spring, just before you begin your summer camping season.

It's best to have your selling dealer or a qualified service technician perform such an inspection. Your dealer may have a "spring special" to perform such inspections.

Particular attention needs to be given to the following items:

1. Exterior vents must be free from obstructions and properly vented to the atmosphere, especially "mud dobber" wasp nests.



WARNING

Do not install screens over the vent for any reason. Screens will become restricted and cause unsafe furnace operation. Accessories are being marketed for RV products which we do not recommend. For your safety, only factory authorized parts are to be used on your furnace.

Examine also for any insects which may have entered, built nests which will cause improper operation. When you find "soot" around your vent it indicates incomplete combustion or contaminated fuel. If such soot is present contact a qualified service center.

2. Inside the furnace cabinet:
 - (a) Inspect areas around combustion chamber for any cracks or leaks causing the flow of exhaust gas being expelled into coach.
 - (b) Inspect and test any propane connections and lines for signs of leakage.
 - (c) Inspect any and all gaskets for leakage or deterioration. Replace if damaged. Any furnace is safe only when there is no leakage from heat chamber.
 - (d) Inspect return air inlet openings to furnace compartment. The furnace cannot operate if return air is restricted from air flow. **DO NOT** store any items around furnace. Return air panel is installed in front of furnace to prevent storage around furnace. **DO NOT BLOCK** this panel.

You, as the owner/user, should inspect the furnace monthly during the heating season for presence of soot on vent. Operating

the furnace under this condition could lead to serious property damage, personal injury or loss of life. If soot is observed on the vent, immediately shut the furnace down and contact a qualified service agency.

2. WATER HEATER

!

WARNING

For your safety, all repairs should be performed by your dealer or a qualified service person.

Since this appliance has burner and pilot assemblies located in an exterior chamber, they are subject to insects and moisture contacts. Spiders especially enjoy propane smell and may build a web across orifices of pilot assembly and in main burner tube. This causes back flashes and sooting of exterior wall and vent assembly.

Should this occur, you must shut system down and clean out any obstructions before continuing to operate.

Also inspect the screen on the door. It must be free of any obstruction including secondary screens. Any such obstructions will proper air flow to both intake and exhaust channels.

Twice per year inspect the grommet around propane copper line entry through the heater jacket as it must be sealed to prevent fumes from carbon monoxide and potential propane leakage to enter coach.

Once per year inspect all wire connections for damage, frayed or looseness. Terminals which are not tight cause heat with potential to melt the wires.

This print shows the correct and incorrect flames in the burner tube. Adjustments may be required.

The anode rod serves two functions: 1) a drain plug for water from the tank to winterize or rinse the system, 2) the element rod is normally made of magnesium or aluminum to absorb impurities and contaminates to prevent damage to the inner tank wall.

It is normal for this rod to “self-destruct” as it draws impurities. When the rod is reduced to 25% of its original condition, it needs to

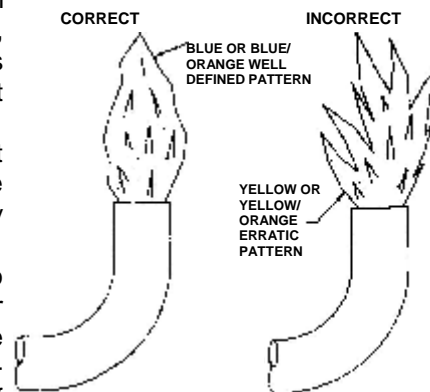



WARNING

Do not replace the anode rod with any non-Suburban accessory part, such as an “add-on” electric heating element. Items such as these are not approved to be installed in Suburban products. They could create an unsafe condition and will also void all warranties.

be replaced, this is not a warrantable item.

Iron and sulfate levels in the water will determine the life of the anode rod.

Operating the water heater without proper anode protection will decrease tank life and will void your warranty on the tank. NOTE: Tank is drained by removing anode rod.

To extend anode life, drain water from tank whenever RV is not being used. Avoid any extended time of non-use with water in tank. Also refer to the section on winterizing.

The sacrificial anode equalizes aggressive water action providing cathodic protection for the tank. The anode is a very important factor in tank life and should only be removed for inspection or draining.

3. STOVE—RANGE—COOK TOP

Each spring before camping season is the best time to inspect your propane consuming appliances for correct operation, plus test all fittings for any possible propane leaks.

You may prefer to have your selling dealer or a good reputable dealer do a “spring checkup” on your coach.

During the usage of your stove and oven it is important to keep your equipment clean for beauty, longer lasting appearance, and operational condition.



WARNING

Be sure all controls are turned off and cooled down before cleaning to avoid burns.

1. Should you experience an overflow accident, be sure to clean up as quickly as possible.
2. Use warm water with a mild soap to clean grates, cook top, and painted or porcelain surfaces. DO NOT use a soap which contains ammonia.
3. DO NOT use abrasive cleaning pads, steel wool or abrasive soap, to clean any surface because of potential scratching of these items.
4. Should any burner parts or orifice become plugged up, use special care:
 - (a) If you use a brush, be sure the bristles do not come loose and lodge in a burner or orifice, later causing more clogging and a fire hazard.
 - (b) Avoid using a wire brush or wire needles. The ends could break off, causing a worse situation. Steel items could also enlarge the holes causing excess fuel usage, raising BTU's, higher heat, and possibly a fire.
 - (c) Use a good cleaning material, possibly alcohol. Soak and rinse. Lightly blow with an air hose rather than using a brush.Soap and warm water are your best solution.

The oven door in the open position is not in a place to permit much weight on it. Excessive weight will cause hinges to bend, springs to stretch, and will prevent the door from closing correctly and sealing when in use.

4. REFRIGERATOR

Maintenance issues on the refrigerator require the following three items to be performed in the every fall, in preparing your coach for winter. Also, you may wish to repeat each spring as needed.

A. Fall

1. Defrost

It is normal for frost to collect on cooling fins inside of the refrigerator. Too much frost, however, decreases cooling efficiency. Defrost as often as desired during summer usage.

After turning off the refrigerator for the winter, remove all food and allow time for defrosting. Then remove the water from the refrigerator using pots, pans and towels. DO NOT attempt to remove ice with any tools.

2. Clean

Now wash the refrigerator completely to a nice clean condition. You may wish to allow the door to remain open slightly to com-

plete the drying process and to prevent any mildew or mold to grow.

Keeping the refrigerator clean will help to avoid any food odors.

NOTE: Do not use abrasive cleaners, chemicals, or scouring pads, because they can damage the interior of the refrigerator. "Dawn," "Fantastic," and "Formula 409" are the brand names of three products that are recommended for use.

3. Ice Maker

To prepare and winterize your ice maker for storage:

1. Close the vehicle water supply valve to the ice maker.
2. Push the ice maker arm up until it locks into the OFF position.
3. Remove the garden hose adapter from the water solenoid valve.
4. Remove the ice maker water line from the water solenoid valve. DO NOT unwrap the water line heater wires from around the water solenoid valve.
5. Drain all of the water from both the water supply line and the ice maker water line.
6. Put the end of the water supply line, the end of the ice maker water line, and the water solenoid valve each into a clean plastic bag.
7. Use tape to close each plastic bag around the water lines and the water solenoid valve.

To use the ice maker after seasonal storage, reverse the procedure above. Be sure to water test the system and fittings.

During winter or any prolonged period of non-use you may want to unplug the 120 volt plug (if possible) and the 12 volt DC terminals. Removing the on board 12 volt battery will serve the same purpose for the 12 volt part.

B. Spring

In the spring or fresh startup, it is highly suggested to spend some time preparing the refrigerator for use

1. Reconnect the 12 volt DC battery, deep cycle suggested, and make sure it is fully charged.
2. Plug in 120 volt AC plug into recept.
3. Door seal should always be tight and not leak air. Place a piece of paper (or a dollar bill) between the door gasket and frame. Close the door and pull the paper out. You should feel a slight drag between the gasket and cabinet. Do this

on all four sides, both top and bottom door.

- If you do not feel a slight drag on the paper, the door does not seal correctly.
 - Have your dealer or an authorized Norcold Service Center correct the seal of the door.
4. Perform a leak test on the propane system (see Chapter 3) to be sure you have not leaks. Inspect the burner tube area to be sure there are no obstructions in this area. Do pressure and operating tests on the propane system.
 5. Venting: Before startup, inspect the venting channels, back side of refrigerator service vent, and be sure there are no obstructions in the roof vent, such as a bird's nest. If air cannot move freely from lower service vent to the roof vent, your refrigerator will not operate and cool properly, and it has the potential of damaging the cooling unit.
 6. Burner: The burner assembly located under the boiler needs to be inspected annually. After opening the burner box door, examine the flame during operation. Flame should be a darker blue inside and a lighter blue outside, and be in a constant, steady shape. If the flame is yellow and/or erratic, your dealer needs to be notified. The burner assembly needs to be clean to operate correctly and efficiently, to allow proper cooling.

Additional maintenance instructions are found in the manual supplied by Norcold, the manufacturer of your refrigerator.

Many of these inspections may be performed by the owner, however most dealers will do "spring specials" for their customers. Contact your dealer for such services to prepare your coach for spring and summer weather.

5. AIR CONDITIONER

Filters in the return air grill are installed to catch dirt, grease, lint, etc. A clogged filter will prevent the correct and required airflow, causing potential "icing up" of the cooling coil.

DO NOT operate the air conditioner without the filter in place.

Cleaning and/or changing the filters:

1. Disengage the two 1/4-turn fasteners that secure the ceiling assembly grille to the ceiling assembly (see figure).
2. Lower the grille and filters from the ceiling assembly.
3. Take filters out and either clean or exchange with other filters (see figure).
4. If the vehicle is equipped with a flush mount ceiling assem-

bly, remove the four return air grill screws. Remove filter from grill and either clean or exchange with new filters.

NOTE: If replacement filters are necessary, the filters can be purchased from most RV Products Authorized Service Centers. It is recommended that spare filters be carried with the RV at all times to replace worn, torn or deteriorated filters.

Clean and/or change the filters every two weeks.

Annually, no more than two years, remove inside screen and torque "4" mounting bolts to insure tightness. If not tight, moisture will enter.

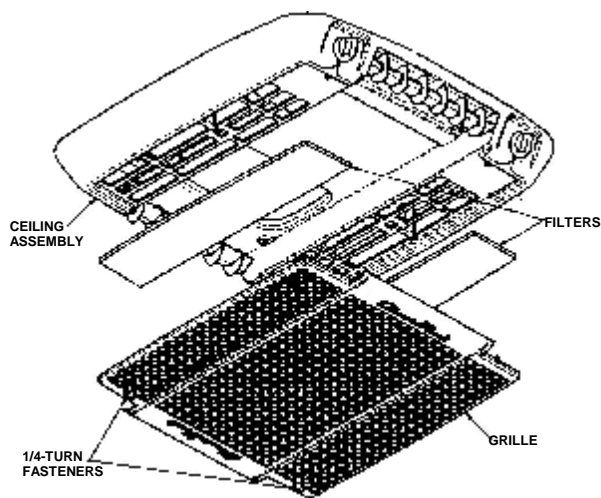

[This page intentionally left blank.]

Chapter V—Interior

1. PANELING

Wall panels in your KZ RV are manufactured with vinyl glued to luan panels.

To clean, use a mild solution of soap and water with a sponge or soft cloth. DO NOT use any abrasive cleaner as scratching of vinyl could occur, causing dull colors and scratches. Avoid cleaners with bleach. For stubborn dirt and stains you may need a stronger all-purpose spray cleaner.

Should deep scratches occur, you may wish to use putty sticks, polish and furniture wax to cover them. Use with care, knowing such repairs cannot completely restore original conditions.

2. LINOLEUM / VINYL FLOOR

To care for and clean vinyl, use a mild soap in water and a damp mop. DO NOT pour water on floor as it may seep under cabinet frames and panels, absorbing water and damaging wood materials. Treat this vinyl as you would in your home.

3. CARPET

Treat your carpet in your recreational vehicle the same as in your home by vacuuming frequently. For tough and deep stains you may need to use a professional cleaning service. Pretest carpet for colorfastness in an inconspicuous area such as under a cabinet.

4. HARDWOOD FLOOR (Optional)

Use only cleaning and waxing products recommended for hardwood floors. Care for hardwood floors in your recreational vehicle as you would in your home.

5. COUNTER TOPS

The surface material is laminated to a substrate wood composite material. A damp cloth or sponge will generally cleanup most food or water spills. Stubborn stains can be removed with general all-purpose cleaners. Be careful to not permit liquid to seep under faucets and sinks potentially causing damage to the substrate material.

6. SOLID SURFACE COUNTER TOPS

While solid surface material is highly heat resistant, an extremely hot pan or baking dish could scorch or crack your counter top. Treat this top the same as your home by using a hot pad or heat absorbing pad to place under your hot dishes.

To clean your tops use cleaning detergents, such as, 409, Fantastic or a bleach-water solution. DO NOT use any abrasive cleaner

on the top.

When pouring boiling or scalding water into sink we suggest running cold water at the same time to avoid too much heat in the sink.

For the sink bowl, use a bleach-water solution, using 1/4 to 1/2 cup of bleach with sink filled to top with water. Let stand for 15-30 minutes. Sink has a different surface and you may use an abrasive cleaner, such as Comet.

For difficult problems:

CLEANING ALL FINISHES

Moist dirt & residue Use soapy water or ammonia based cleaner, rinse and wipe dry.

Water marks Wipe with damp cloth and wipe dry

Difficult residue Spray residue with Cleaner for DuPont Corian® from Stone Care International, wait for about 30 seconds for cleaner to work. Wipe dry with a paper towel. If residue persists, repeat process. If residue still persists, follow directions for removing scratches.

Disinfecting Occasionally wipe surface with dilute household bleach (1 part water/1 part bleach). Rinse top thoroughly with water and wipe dry.

REFURBISHING FINISHED GLOSS LEVEL

Matte Rub entire surface with a green Scotch-Brite®* pad in a circular motion. Rinse surface with water and wipe dry.

Semi-gloss Use a countertop polish to help hide scratches and blend in a uniform gloss level.

High-gloss Follow steps for semi-gloss or contact your dealer to arrange for professional refurbishment.

SINKS & LAVATORIES

Cleaning Follow procedures above or use Soft Scrub®** and a green Scotch-Brite®* pad to remove residue. Rub green Scotch-Brite®* pad over entire sink to blend in finish.

Disinfecting Occasionally fill sink 1/4 full with diluted household bleach (1 part water/1 part bleach). Let stand for 15 minutes, then wash sides and bottom as solution drains. Rinse sink with water.

7. WINDOW MINI BLINDS (Kitchen Window)

Blinds and rails are made of pre-painted aluminum metal. Clean these blinds by using a soft damp cloth or sponge to remove dust. Blind can be removed from mounting brackets for additional or extensive washing.

Some professional dry cleaners have equipment to clean these shades and immerse them in a liquid cleaner.

8. DAY FABRIC SHADES

To clean pleated day-night fabric shades of dust, use a soft-attachment of a vacuum cleaner. To remove solid spots on fabric use clear Ivory dishwashing liquid and water. For aluminum rails use "409" cleaner.

9. ABS PLASTIC COMPONENTS

Bath tub, shower wall, toilet and the lavatory sink are made from ABS plastic. DO NOT use any type of abrasive type cleaner as it will scratch the plastic. Use only mild detergent with warm water for cleaning.

10. SOFT TOUCH CEILING (Optional)

Through normal use the fabric may become soiled and contaminated, requiring spot cleaning occasionally. The fabric is made from either polypropylene or polyester fibers, which are synthetic materials. Vacuuming the material is the first and easiest choice.

For more stubborn or difficult stains use carpet and upholstery cleaners. You can also use detergent cleaners or even high strength detergent when the extra effort is desired.

REMEMBER—this is polypropylene, basic plastic, so don't be afraid to clean it.

11. DRAPES

Materials used in the drapes of your recreational vehicle consist of different cotton and polyester combinations. Frequent vacuuming is recommended as the first choice of cleaning. Using a damp cloth in warm water with detergent soap, spot clean soiled spots.

12. CUSHION COVERS

Any fabric cushion covers with vinyl on the bottom side should not be dry cleaned. Dry cleaning could cause the vinyl to become hard and crack, and could also remove the stain retardant placed into the fabric. Vacuum the cushion covers whenever the need arises. For difficult spots may need to remove covers and contact a professional cleaning service. DO NOT dry clean covers as they may shrink.

13. FURNITURE

Upholstered items such as recliners, swivel rockers, rocker recliners, sofas and other free standing pieces may be cleaned by frequent vacuuming or light brushing to remove dust and to prevent overall soiling.

On some spots you may wish to use a detergent soap and water to attempt to clean a spot. If it fails you may need to seek the service of a professional cleaner.

14. WINDOWS

On window(s) which have opening sliders or awning panel, there are "weep or drain" holes at lower sections of frame extrusions, generally at the end of each movable panel. Dirt, debris, insects, etc. can and will accumulate, potentially plugging up these weep holes. Should water accumulate, stand in threshold of window, your weep holes and / or channels in window have become plugged.

Be sure to keep these drainage areas open at all times.

Should water be draining out and window still runs over to inside, you have a leak problem or excessive condensation problem. See Chapter 1 in owners manual for condensation concerns and solutions.

15.SMOKE ALARM

Maintenance: This smoke alarm has been designed to be as maintenance free as possible, but there are a few simple things you must do to keep it working properly

- Test each smoke alarm at least once a week.
- Keep a supply of approved 9-volt replacement batteries on hand.
- Test each smoke alarms used in RVs after vehicle has been in storage, before each trip and at least once per week during use. Failure to test smoke alarm used in RV's as described may remove your protection.
- Gently vacuum off any dust on your cover of the smoke alarm monthly with your vacuum's soft brush attachment. Test unit once you have vacuumed the cover.
- Never use water, cleaners or solvents since they may damage the smoke alarm.
- Relocate the smoke alarm if it sounds frequently with unwanted alarms. See section "Locations Where Smoke Alarms Should NOT be installed".
- When the battery becomes weak, the unit will "beep" about once

a minute (the low battery warning). This, low battery warning should last for 30 days, but you should replace the battery immediately once the unit starts “beeping” (“the low battery warning”).

- Replace you Smoke Alarms at least every 10 years. This includes models with 10-year batteries (SA-668LL and SA-668SLL). Manufactured date code is on the back of the alarm.

16.PROPANE AND C.O. DETECTOR—COMBO:

HOW TO TAKE CARE OF YOUR ALARM

This CO/Propane Gas Alarm is designed to be as maintenance free as possible. To keep your alarm in good working order, you must:

TEST THE ALARM WEEKLY. See the section, **Test Procedure**, in this manual for further information.

VACCUM THE DUST OFF THE ALARM COVER. At least once a year (more frequently in dusty locations), use the soft brush attachment of your vacuum to clean the alarm cover.

CLEAN THE ALARM COVER WHEN DIRTY. Wash the alarm cover by hand. Use a cloth dampened in clean water. Dry with a soft cloth.

DO NOT SPRAY CLEANING AGENTS OR WAXES DIRECTLY ONTO THE FRONT PANEL. This action may damage the sensor, cause an alarm or cause an alarm malfunction.

OBSERVE THE COLOR OF THE INDICATOR LIGHT. At frequent intervals and during your weekly test, check the indicator light on the front panel of the alarm.
See section, **Operation**, in the manual for further information.



TEST PROCEDURE WARNING

TO REDUCE THE RISK OF CARBON MONOXIDE POISONING OR PROPANE GAS EXPLOSION, TEST THIS ALARM'S OPERATION AFTER THE RV HAD BEEN IN STORAGE, BEFORE EACH TRIP AND AT LEAST ONCE PER WEEK DURING USE.



WARNING

DO NOT USE A CIGARETTE LIGHTER TO TEST THE CO/ PROPANE GAS ALARM. Butane gas may damage the sensors.

DO NOT attempt to test the alarm by any other means than by using the TEST/RESET button. DO NOT attempt to produce CO—to test the alarm. The TEST/RESET button tests all functions of the alarm and is the ONLY safe way to be sure the alarm is working properly.

The alarm may be tested at any time—The TEST/Mute switch is located on the front of the alarm Press and hold the test button for 1 second. The Alarm is working properly if the GREEN indicator light changes color to RED and the horn beeps 4 times. The gas LED should also blink Red.

IMPORTANT— If this alarm does not test properly return it immediately for repair or replacement.